POWER from the SUN

Mini-Grid PV Installations



Presentation Outline

- **PV-Options and Potentials**
- **PV-Mini Grid Application**
 - **Objectives**
 - **Design Considerations**
 - **Examples**
- **PV-Grid Connected Generators**
 - **Design and technical Standard**
 - **Contribution and Promotion**
- **Economic Considerations**



PV-Basics



Solar Harvest

- The Sun gives $63,000 \text{ kW/m}^2$
- Earth receives $1,360 \text{ W/m}^2 = \text{Solar Constant}$
- $1,000 \text{ W/m}^2$ reaches the ground at clear sky
- Heat emission converted thermally to 700 W/m^2
- Light energy converted electrically to 100 W/m^2

1360 Watt
pro m^2



PV-Basics



Solar Profile

- **Medium irradiation**
Fiji 5.074 (Hamburg 2.890) kWh/m²/day
- **Annual receipt is**
Fiji 1.852 (Hamburg 1.054) kWh/m²/year
- **A 50 m² roof in Fiji**
can produce from that ~9.000 kWh/year
electricity
- **Tilt affects the solar**
harvest

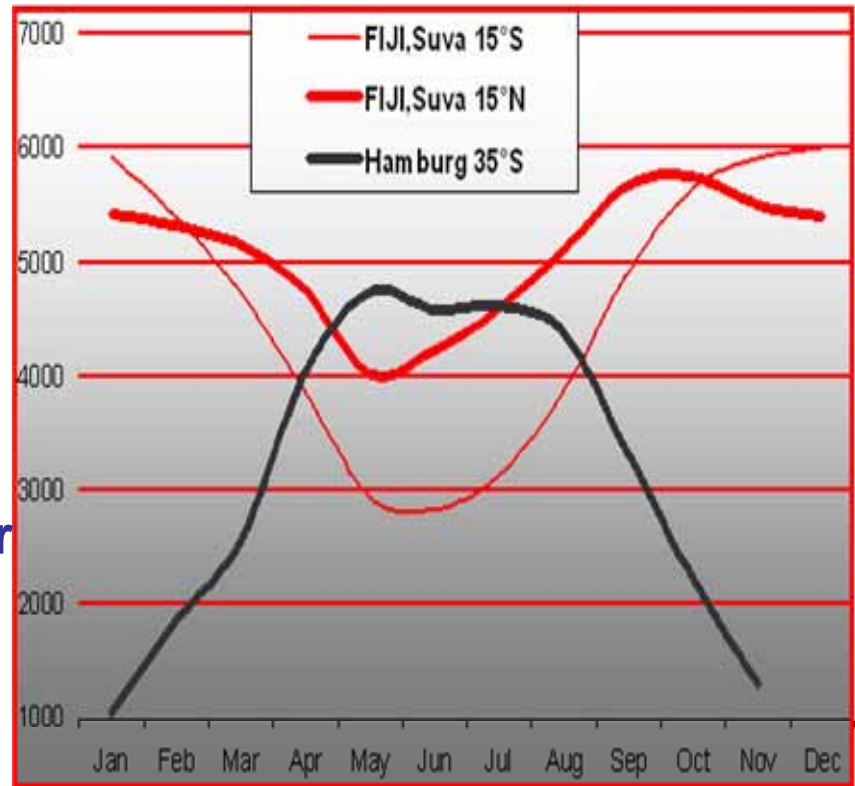

PV-Selections

RE Sources



Available

- **Grid Support**
- **GeneratorSet**
- **Hydropower**
- **Windpower**
- **Biomass**
- **Biogas**
- **Solar Heater**

Augmentable

- **Grid-Connected PV**
- **Mini-Grid PV**
- **Community Systems**

- supplemental only**
- **PV-Pumps**
- **Solar Home Systems**
classic, comfort, AC, DC
- **Small-PV**
Lanterns, Battery Charging

PV-Selections



Area Development

Dynamic Supply Development

Naturally, Demand

- **Increases**
requires extension of
generation
- **Spreads in Area**
requires expansion of
service

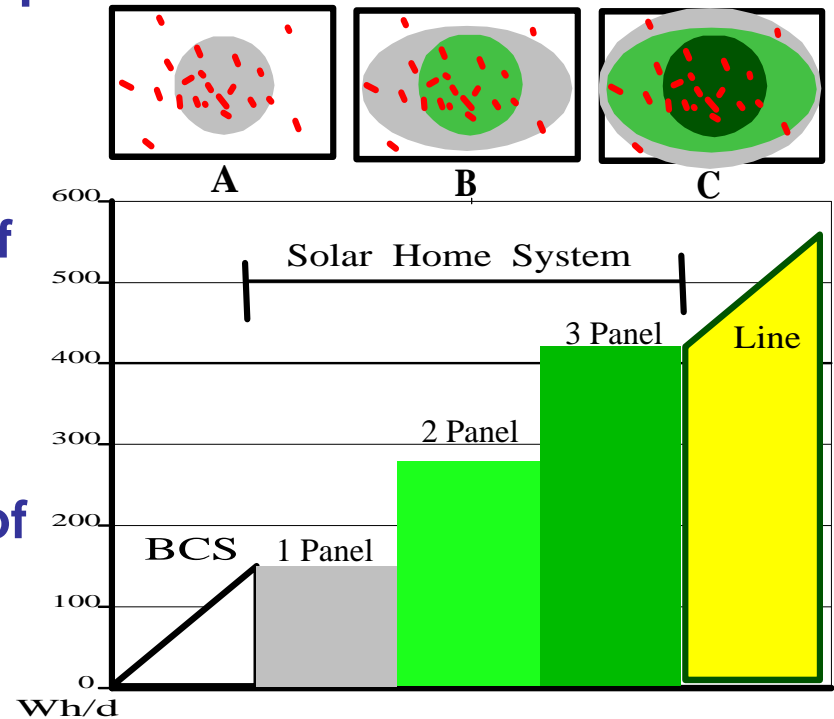

PV-Selections

Small PV-Options



- **Village Lantern System 50W**

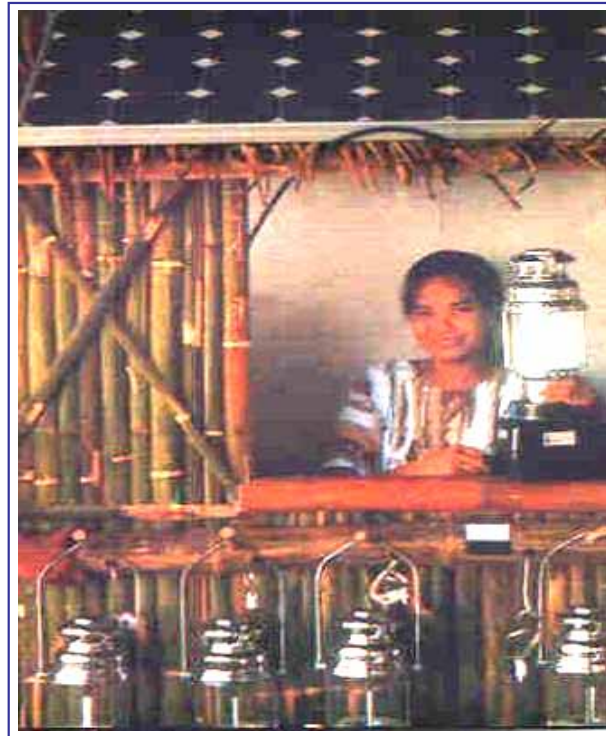

PV-Selections

SmallPV-Options

- **Solar Home System**



PV-Selections



Small PV-Options

- **Battery Charging Station 200W**



PV-Selections



Decentralized Applications

- **DC Systems:**
- Stand Alone System
- PV Pumping

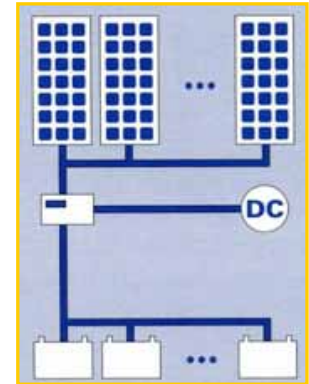
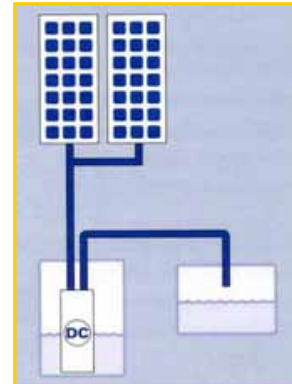
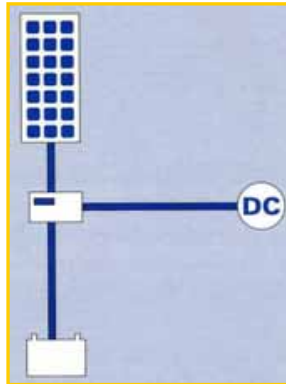

- **AC Systems:**
- AC/DC Supply
- Full AC
- Hybrid System

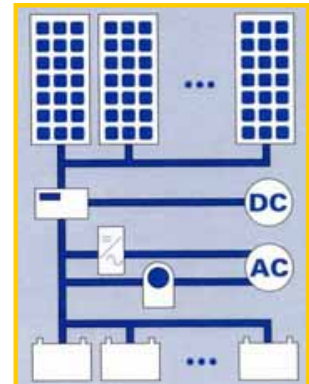
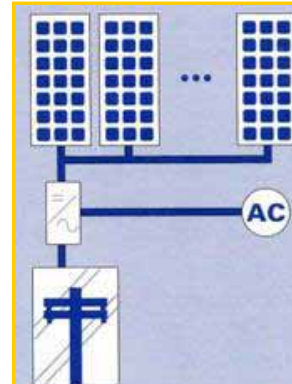
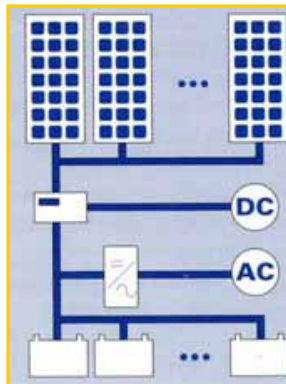

Mini-Grid

Designing Mini-Grid



- **Distribution Lines and Operations**
 - Manageable for single users
 - Load management required for multiple users
- **Battery sizing and quality crucial**
 - Small = heavy cycling, energy loss
 - Cheap = Short life-cycle, costly

Mini-Grid

Sizing Mini-Grid Components



- **Motor Generators**
= Power design
- **Battery based generators**
= Energy design

Mini-Grid

Mini-Grid Concepts



● DC Bus

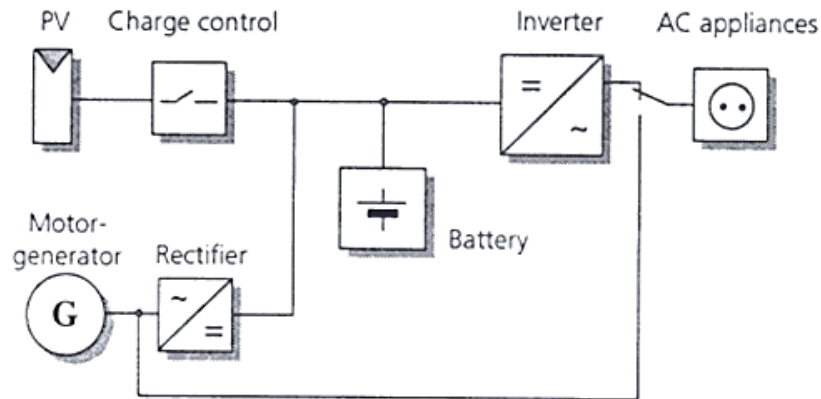

● AC Bus

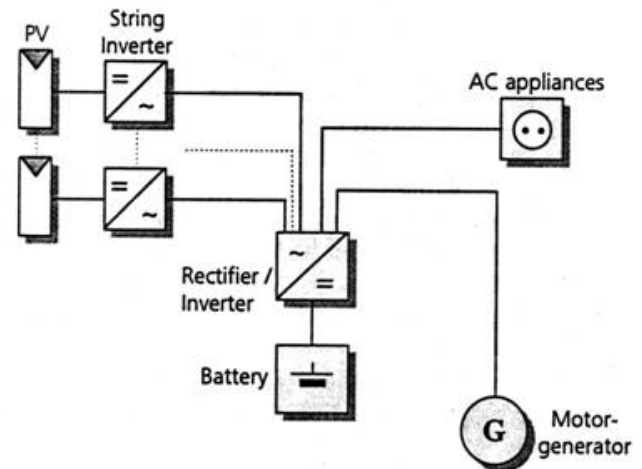

Mini-Grid

Mini-Grid Concepts



- Typical DC Bus Design (Wind)

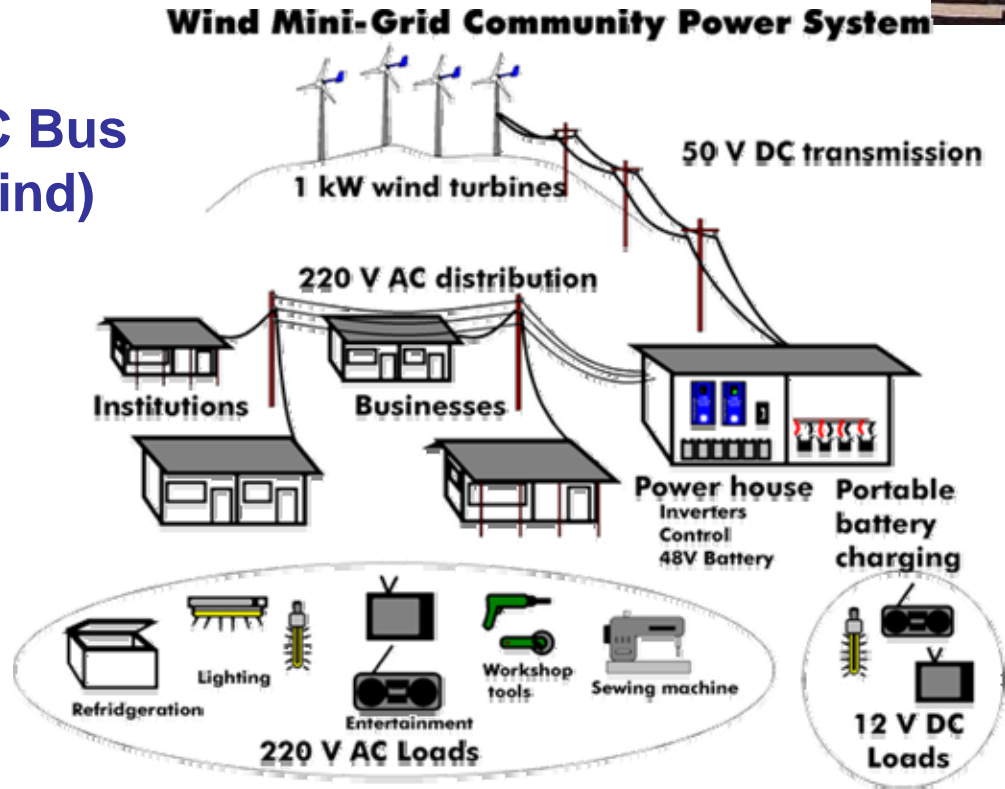

Mini-Grid

Hybrid Installations



- **Compact
PV-Hybrid
Installation**



Mini-Grid

Objectives for Hybrid Installations



- **Better Cost/Benefit Ratio**

- **Peak Load** (seasonal supplement)
- **Independence**
(grid failure, fuel shortage, genset breakdown)
- **Security** (backup, peak load, autonomy)
- **Grid Healing** (voltage drops, peak consumption)

Mini-Grid

Combining Hybrid Components



- **Analyse Consumption Profile**
- **Day / Night ratio = modelling helps**
- **High, constant load = Motor Generators**
- **Short load peaks = Battery/Inverter**
- **Small, essential load = PV based**

Mini-Grid

The AC-Bus



- Expandable (1- and 3-phase, parallel)
- Optimum battery life by smart battery-, load-, and grid management
- Comfortable Diagnosis (maintenance, remote sensing)

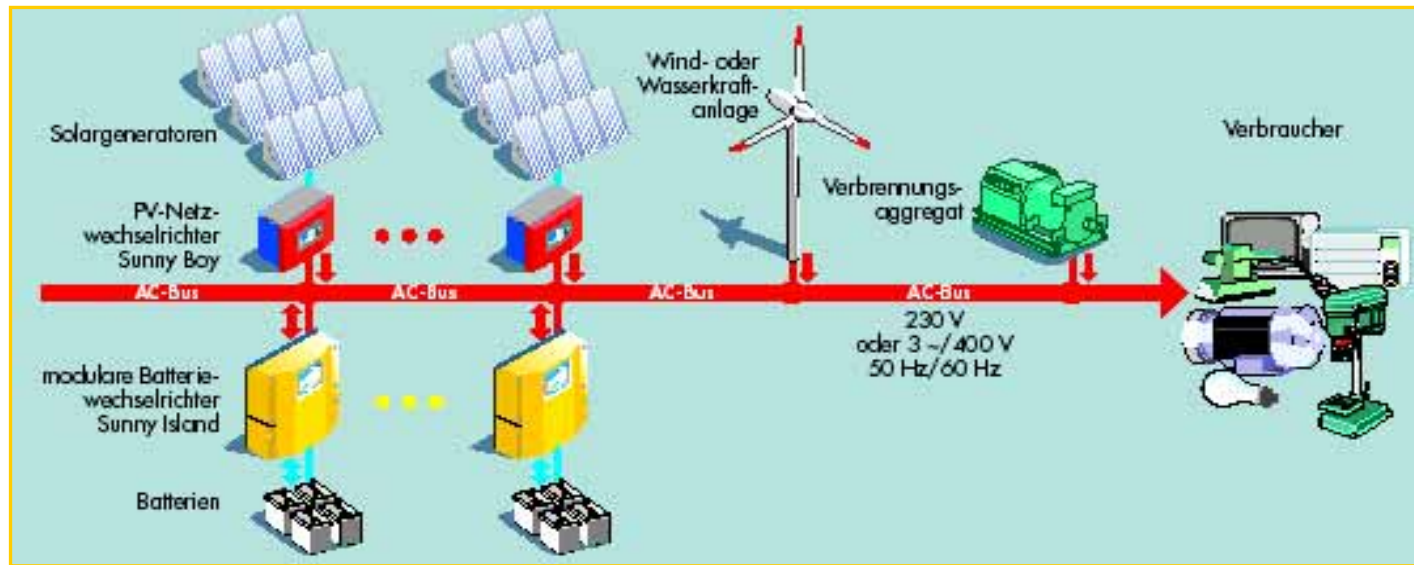

Mini-Grid

The AC-Bus

- Bi-directional battery-inverter
- Better quality than public grid
- Modular combination of PV-, wind-, dieselgenerators
- Simplified design of independent grid by coupling all components on the AC bus
- Applicable from single home to village size (3 to 30 kW)



Mini-Grid

Philippines Mini-Grid



- Started 12 kWp
Sampaloc

- Transferred 6 kWp
Verde Island

- Downsized to
2 kWp



Mini-Grid

Gobabeb Mini-Grid

- **Supply Side**
 - 26 kWp PV Generator
 - 200 kWh/120Vdc Battery
 - 30 kVA bidirectional Inverter (AES static power pack)
 - 2x50 kVA GenSet, underused
 - Remote Monitoring
 - Uninterrupted power changing inverter/generator and vice versa
 - Variable battery charge
 - Parallel operation with diesel generator
- **Demand Side**
 - Energy efficiency retrofits
 - Load training
 - Competition



Grid Systems

Components

- (1) Solar Generator
- (2) Group box & wiring
- (3) Mounting structure
- (4) Inverter
- (5) Meter

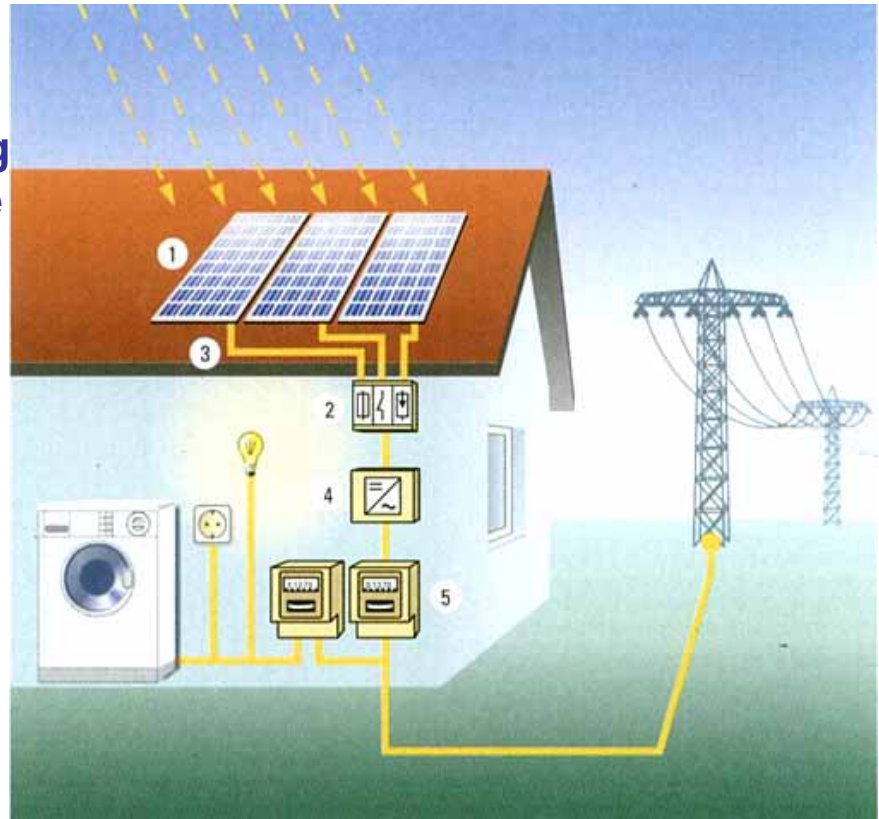

Grid Systems

Power Density Solar Cells



Area Use of different Base Material :

- **Monocrystalline** 110-130 W/m²



- **Polycrystalline** 100-125 W/m²

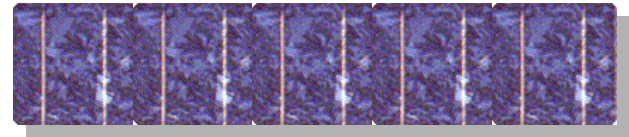

- **Amorphous** 40-80 W/m²



Grid Systems

Panel Selection



Crystalline Solar Panels

- Good results at ideal orientation
- Good for tilted mount
- Less mounting cost
- Inverter
 - electronic
 - compact

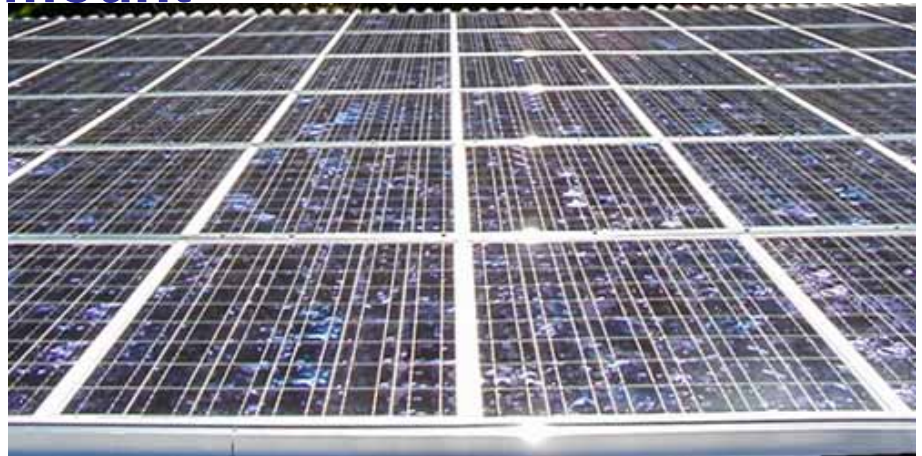

Grid Systems

Panel Selection



Thin-Film Solar Panels

- Good at irregular orientation, large surface
- Good in warm climate
- Attractive Cost
- Inverter need transformer



Grid Systems

Generator Design



- **Panel:**

- Series-connection Cells

- Hot-Spot

- Bypass

- **Generator:**

- Series-connection Panels

- Shading

- Matching

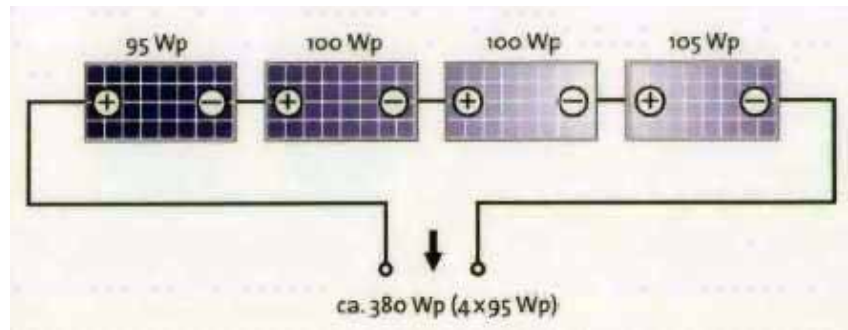
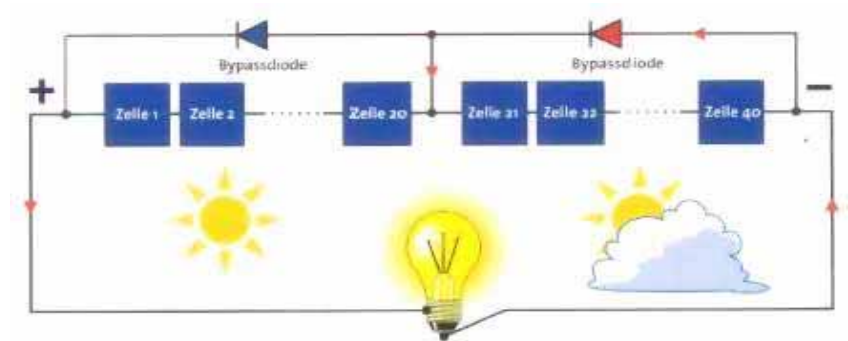

Grid Systems

Mounting Concepts



- On-Roof



- In-Roof



- Tilted

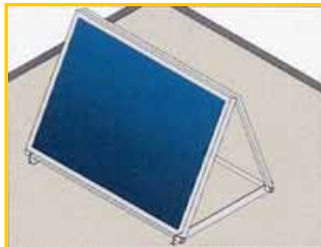

- Shade

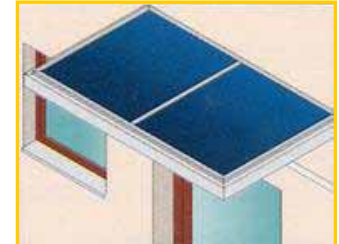

- Full Roof



- Facade



Grid Systems



Inverters

- **Performance**
 - Efficiency (european)
 - Power Range
 - Voltage Range
 - Max Voltage
- **Design**
 - Transformer
 - Connectors
 - Interface
 - Display
 - protection
- **Concept**
 - String / parallel
 - Master / Slave
 - Multistring / Team



Grid Systems



Design

- **Sizing Generator**
 - Available Area
 - Regulations
 - Panel Type
 - Customer's Plan
- **Sizing Inverter**
 - Generator Power
 - Stringlengths
- **Sizing Components**
 - Mounting Structure
 - Wiring
 - Connection Boxes
 - Meter Cabinet
- **Cost Calculation**



PV-Economics

German Support Program EEG

- **Feed-in-Law**
- **Guaranteed purchase for 20 years at rates around 0,82 F\$**
- **Privately owned, operated**
- **Safe Investment**
- **Inspired a PV boom over 500 MW/y**
- **Adopted in Spain, Italy, Greece ...**
- **Goal RE < 20% by 2020 attainable**



PV-Economics



Support Alternatives

- **Tax Benefits**
- **Quota**
- **Comparative Application :**

Application	Lines	Energy	Battery	Subsidy	Service	Metering
Small Solar	no	medium	small	yes	provider	no
MiniGrid, single	yes	medium	yes	no	user	no
MiniGrid, multiple	yes	more	yes, sorry	yes	provider	yes
Grid-connected	yes	full	no	no	user	basic

PV-Economics

Legalities

- **Feed-in Law**
- **Contractor's regulations**
- **Payment terms (commissioning)**
- **Warranty**
- **Power guaranty**
- **Product guaranty**
- **Guaranty extension**
- **Remedies**



Heinz-Wolfgang Böhnke

www.TECHNOSOL.de

**Thank You for
Your
Attention!**

